



**NIEUWKOOP**

# USER MANUAL



## DP1110 DOSING PUMP



TO MEASURE  TO KNOW



## **GENERAL WARNING**

### **GENERAL PRESCRIPTIONS**

We would like to thank you for choosing this product, it is recommended to read the handbook carefully, before proceeding to the installation of the dosing pump, lend particular attention to the warnings of emergency marked from graphic symbol.

The respect of the norms and the prescription reported can assure a safe and appropriate participation. The handbook and maintenance constitute an integral part of the machine and it must be available to the assigned staff for its use and maintenance, therefore it is necessary to conserve it integrate in a safety place.

### **TECHNICAL ASSISTANCE**

The ordinary and extraordinary maintenance must be in agreement to the instructions in the present handbook. For all the cases and every kind of assistance we recommend to contact directly the constructor by referencing to data sheet inserted in the pump's label.

- **Model of the pump.**
- **Serial number**
- **Year of construction.**

In case the maintenance of the pump is executed in an unconformable way to the supplied instructions, or can prejudice the integrity or modify the characteristics, the constructor will be considered relieve from whichever responsibility inherent to the security of the persons and the defective operation of the pump. For every kind of technical assistance and demands for replacement parts it is recommended to contact the headquarter.

Nieuwkoop BV P.O. BOX 78 – 1430 AB Aalsmeer

Commercial Department: Ph. +31 297 325836 – fax +31 297 323167

Web: [www.meten.nl](http://www.meten.nl)

E-mail: [info@nieuwkoopbv.nl](mailto:info@nieuwkoopbv.nl)

## **RESPONSIBILITY**

The lack of respect of the instructions included in the handbook and the maintenance will exempt the constructor from whichever responsibility.

For any data sheet that it is not included and not deducible from the pages to follow, we recommend to consult directly the constructor.

## **INFORMATION TO THE CONSUMERS**

To the Senses Of the article 13 and the legislative decree of July 25 2005, n 151 " realization directives 2002/95/CE, 2002/96/CE, 2003/108/CE related to the reduction of the use of dangerous substances in the electric equipments and electronics, as well as to the disposal of the refusals.



The symbol "cross chest" brought on the equipment points out that the product at the end of its function cannot be digested as normal urban refusal.

The consumer must confer the equipment to the fit centers of diversified harvest of the electric and electronic refusals, or to redeliver it to the retailer during the purchase of a new equipment.



The suitable diversified harvest contributes to avoid possible negative effects on the environment and on the health and favors the retrain of the materials of which the equipment is composed.

The unauthorized disposal from the consumer involves the application of the administrative sanctions of which "article 50 and following of the D. Lgs. n. 22/1977."



## CONFORMITY DECLARATION

DECLARES:

That THE ELECTROMAGNETIC PUMPS  
**SDP** Series  
Type **SMC - SML**

They have been planned and realized in the following conformities with directions and specifications

Electromagnetic compatibility CEM 89/336/CEE  
Low voltage n. 73/23/CEE with modification n. 93/68/CEE

Signed by: MICCICHE' TULLIO  
Charged by: Responsible of quality



INDEX

<b>1</b>	<b>HINTS AND WARNINGS</b> .....	<b>5</b>
1.1	WARNINGS.....	5
1.2	SHIPPING AND TRANSPORTING THE PUMP.....	5
1.3	PROPER USE OF THE PUMP.....	5
1.4	RISKS.....	5
1.5	TOXIC OR DANGEROUS LIQUID DOSAGE.....	6
1.6	ASSEMBLING AND DISASSEMBLY THE PUMP.....	6
	1.6.1 ASSEMBLY.....	6
	1.6.2 DISASSEMBLY.....	6
<b>2</b>	<b>METERING PUMPS SDP series SMC – SML type</b> .....	<b>7</b>
2.1	OPERATION.....	7
2.2	TECHNICAL SPECIFICATIONS.....	7
2.3	LIQUID ENDS MATERIALS.....	8
<b>3</b>	<b>INSTALLATION</b> .....	<b>8</b>
3.1	INJECTION VALVE INSTALLATION.....	10
3.2	MANUAL STROKE LENGTH ADJUSTMENT type SMC-R and SML-R.....	10
3.3	WIRING CONNECTION AND OUTPUT CONNECTOR FUNCTIONS.....	11
<b>4</b>	<b>MAINTENANCE</b> .....	<b>11</b>
<b>5</b>	<b>HOW TO OPERATE WHEN DOSING SULPHURIC ACID</b> .....	<b>11</b>
<b>6</b>	<b>MANUALLY OPERATED METERING PUMP</b> .....	<b>12</b>
6.1	PUMP CONTROLS.....	12
6.2	TYPICAL INSTALLATION.....	12
6.3	ACCESSORIES.....	12
<b>7</b>	<b>TROUBLE-SHOOTING COMMON TO SDP SERIES PUMPS</b> .....	<b>13</b>
7.1	MECHANICAL FAULTS.....	13
	7.1.1 THE METERING PUMP GIVES PULSES BUT THE ADDITIVE IS NOT INJECTED.....	13
7.2	ELECTRICAL FAULTS.....	13
	7.2.1 ALL LEDS OFF, THE PUMP DOES NOT PULSE.....	13
	7.2.2 GREEN LED (POWER) ON RED LED (PULSE) OFF, THE PUMP DOESN'T PULSE.....	13
	7.1.4 PUMP PULSES AREN'T CONSTANT.....	13
	7.1.5 THE DOSING PUMP GIVES ONLY ONE PULSE.....	13
	7.1.6 SWITCHING-ON DELAY.....	13
	<b>DRAWINGS AND DETAILS</b> .....	<b>14</b>



## **1 HINTS AND WARNINGS**

### **1.1 WARNINGS**

Please read the warning notices given in this section very carefully, because they provide important information regarding safety in installation, use and maintenance of the pump.

N.B. The pump has been constructed in accordance with best practice. Both its life and its electrical and mechanical reliability will be enhanced if it is correctly used and subjected to regular maintenance.

#### **ATTENTION!**

**Any intervention or repair to the internal parts of the pump must be carried out by qualified and authorized personnel. The manufacturers decline all responsibility for the consequences of failure to respect this rule.**

#### **GUARANTEE!**

1 year (the normal wearing parts are excluded, i.e. valves, nipples, tube nuts, tubing, filter and injection valve. Improper use of the equipment invalidates the above guarantee. The guarantee is ex factory or authorized distributors.

### **1.2 SHIPPING AND TRANSPORTING THE PUMP**

The pump should always be moved in a vertical position and never in a horizontal position. The shipment with whichever forwarder is done, even if it is (CPT) carried paid to the address of the purchaser or addressee, one agrees carried out to risk and danger of the purchaser. Claims for any missing materials must be made within 10 (ten) days of the arrival, while claims for defective materials will be considered up to the 30th (thirtieth) day following receipt. Return of pumps or other materials to us or the authorized distributor must be agreed beforehand with the responsible personnel.

### **1.3 PROPER USE OF THE PUMP**

The pump should be used only for the purpose for which it has been expressly designed, namely the dosing liquid additives. Any different use is to be considered improper and therefore dangerous. The pump should not therefore be used for applications that were not allowed for in its design. In case of doubt, please contact our offices for further information about the characteristics of the pump and its proper use.

The manufacturer cannot be held responsible for damage deriving from improper, erroneous or unreasonable use of the pump.

### **1.4 RISKS**

- After unpacking the pump, make sure it is completely sound. In case of doubt, do not use the pump and contact qualified personnel. The packing materials (especially bags made of plastics, polystyrene, etc.) should be kept out of the reach of children: they constitute potential sources of danger.
- Before you connect the pump, make sure that the voltage ratings, etc correspond to your particular power supply. You will find these values on the rating plate attached to the pump.
- The electrical installation to which the pump is connected must comply with standards and good practice rule in force in the country under consideration.

Use electrical equipment always implies observance of some basic rules. In particular:

- ✓ Do not touch the equipment with wet or damp hands or feet.
- ✓ Do not operate the pump with bare feet (example: swimming pool equipment).
- ✓ Do not leave the equipment exposed to the action of the atmospheric agents.
- ✓ Do not allow the pump to be used by children or unskilled individuals without supervision.



In case of breakdown or improper functioning of the pump, switch off; but do not touch. Contact our technical assistance for any necessary repairs and insist on the use of original spares. Failure to respect this condition could render the pump unsafe for use.

When you decide to make no further use of an installed pump, make sure to disconnect it from the power supply.

**Before carrying out any service on the item, check:**

- 1** Disconnect the pins from the mains or by means of a two poles switch with 3 mm minimum distance between the contacts (Dwg. 4).
- 2** Relieve all the pressure from the pump head and injection tube.
- 3** Drain or flush all dosing liquid from the pump head. This operation can also be done with the pump disconnected from the plant by turning the pump upside-down for 15 to 30 seconds and without connecting the tubing to the nipples: if this operation is not possible, dismount and remount the pump head using the four mounting screws.

In event of possible losses in the hydraulic system of the pump (breakage of the "O" ring gasket, the valves or the hoses) the pump should immediately be brought to a stop, emptying and depressurising the delivery hose while taking all due safety precautions (gloves, goggles, overalls, etc.)

## 1.5 TOXIC DANGEROUS LIQUID DOSAGE

To avoid risk from contact with the hazardous liquids or toxic fumes, always adhere to the notes in this instruction manual:

- Follow the instructions of the dosing liquid manufacturer
- Check the hydraulic part of the pump and use it only if it is in perfect condition
- Use only the correct materials for the tubing, valves and seals to suit the liquid to be dosed; where possible shield the tubing with PVC conduit.
- Before disconnecting the metering pump, make sure to flush out and neutralize the pump head with the proper reagent liquid.

## 1.6 ASSEMBLING AND DISMANTLING THE PUMP

### 1.6.1 ASSEMBLY

All metering pumps are normally supplied fully assembled. For greater clarity, please consult the exploded view of the pump appended at the end of the manual, which shows all the pump details and a complete overview of all the pump components. These drawings are in any case quite indispensable whenever defective parts have to be re-ordered. For the same purpose, the appendix also contains other drawings showing the hydraulic parts (pump head and valves)

### 1.6.2 DISASSEMBLY

Proceed as follow before you dismantle the pump or before performing any other operation on it:

- ✓ Disconnect the pins from the mains or by means of a two poles switch with 3mm minimum distance between the contacts (Dwg. 4).
- ✓ Relieve all the pressure from the pump head and injection tube.
- ✓ Drain or flush all dosing liquid from the pump head. This operation can also be done with the pump disconnected from the plant by turning the pump upside-down for 15 to 30 seconds and without connecting the tubing to the nipples: if this operation is not possible, dismount and remount the pump head using the four mounting screws (Dwg. 10).
- ✓ This operation calls for special attention, and you should therefore consult the drawing in Appendix and Chapter **1.4 "RISKS"** before you commence work.

## OVERALL DIMENSIONS

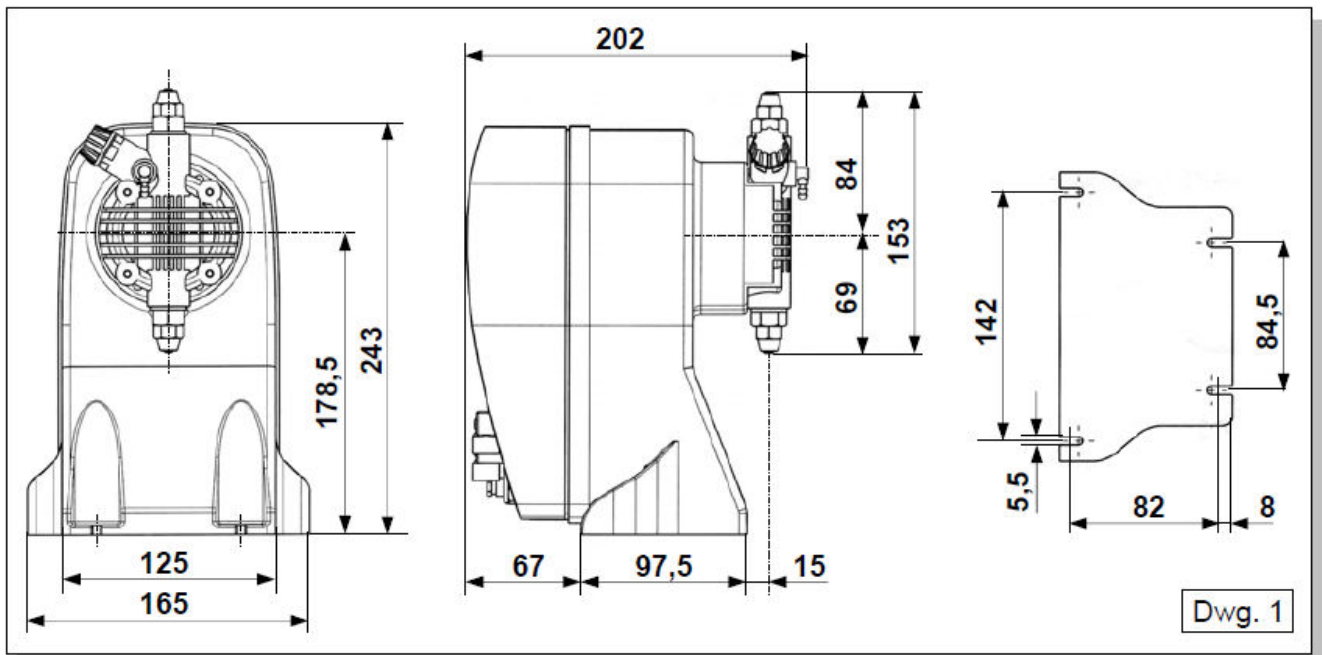

## 2 METERING PUMPS SDP series, SMC - SML type

### 2.1 OPERATION

The metering pump is activated by a Teflon® diaphragm mounted on a piston of an electromagnet. When the piston of the electromagnet is attracted, a pressure is produced in the pump body with an expulsion of liquid from the discharge valve. Once the electric impulse is finished a spring brings the piston back to the initial position, with a recall of liquid through the suction valve.

The operation is simple the pump does not need lubrication, therefore maintenance is reduced almost to zero. The materials used for the construction of the pump make it particularly suitable for aggressive liquids.

The metering pump has been designed to feed liquids with capacities from 0 to 20 l/h and pressures from 0 to 20 bar (depending on the model selected)

### 2.2 TECHNICAL SPECIFICATIONS

- ✓ The products are manufactured according CE regulation.
- ✓ Antiacid plastic casing.
- ✓ Control panel protection assured by an adhesive polyester film, weatherproof and resisting UV ray.
- ✓ Standard power supply (fluctuations not to exceed  $\pm 10\%$ ): 230V a.c. 50Hz single phase.
- ✓ Optional power supply (fluctuations not to exceed  $\pm 10\%$ ): 240V a.c. 50-60Hz single phase.
- ✓ 110V a.c. 50-60Hz single phase.
- ✓ 24V a.c., 24V d.c., 12 V d.c.
- ✓ Over voltage cat. II
- ✓ Environmental Conditions: IP65 protection, altitude up to 2000 m, ambient temperature 5°C to 40°C, maximum.
- ✓ Relative humidity 80% for temperatures up to 31°C decreasing linearly 50% relative humidity at 40°C
- ✓ Pollution degree 2
- ✓ Upon request: manual stroke length adjustment. This control provides accurate flow adjustment (only SMC-R and SML-R).



## 2.3 LIQUID ENDS MATERIALS

- **DIAPHRAGM:** PTFE
- **PUMP HEAD:** Polypropylene, upon request; PVC, S.S. 316 , PTFE, PVDF
- **NIPPLES:** Polypropylene
- **FILTER:** Polypropylene
- **INJECTION NIPPLE:** Polyethylene
- **SUCTION HOSE:** PVC flexible
- **DISCHARGE HOSE:** Polyethylene
- **VALVES:** "lip type": FPM, (upon request available in EPDM end NBR, SILYCON
- **9 VALVES:** upon request type in SS 316, Glass Pyrex, ceramic
- **10 SEALS:** FPM upon request EPDM, NBR, SILYCON, PTFE.

Technical data pumps SMC - SML Type										
Type	Max flow	Output/stroke	Max press.	Stroke	Impulse n°	Power comp.	Corrent comp.	Connections	Suction height	Weight
	l/h	ml/imp.	bar	mm	Imp./min	Watt	Ampere	Øe / Øi	m.c.l.	kg
115	1	0,14	15	0,8	120	37	0,16	06/04	2	3,5
	2	0,28	10							
	3	0,42	5							
	5	0,69	2							
210	2	0,28	10	0,8	120	37	0,16	06/04	2	3,5
	3	0,42	7							
	5	0,69	4							
	7	0,97	2							
220	2	0,28	20	1	120	58	0,25	06/04	2	3,5
	3	0,42	10							
	4	0,56	5							
	5	0,69	3							
507	5	0,69	7	1	120	37	0,16	06/04	2	3,5
	7	0,97	4							
	8	1,11	2							
512	5	0,69	12	1	120	58	0,25	06/04	2	4,1
	7	0,97	5							
	10	1,39	2							
810	8	1,11	10	1,4	120	58	0,25	06/04	2	4,1
	10	1,39	5							
	13	1,81	2							
154	15	2,08	4	2,2	120	58	0,25	06/04	2	4,1
	16	2,22	2							
	17	2,36	1							
203	20	2,78	3	2,2	120	58	0,25	06/04	2	4,1
	22	3,05	1							

The indicated capacity value is subject to change due to the working pressure, the dosed liquid and the viscosity.

## 3 INSTALLATION

A Install the pump in a dry place and well away from sources of heat and, in any case, at environmental temperatures not exceeding 40°C. The minimum operating temperature depends on the liquid to be pumped, bearing in mind that it must always remain in a liquid state.





**B** Carefully observe the regulations in force in the various countries as regards electrical installations the (Dwg. 4). When the supply cable is devoid of a plug, the equipment should be connected to the supply mains by means of a single-pole circuit breaker having a minimum distance of 3 mm between the contacts. Before accessing any of the electrical parts, make sure that all the supply circuits are open.

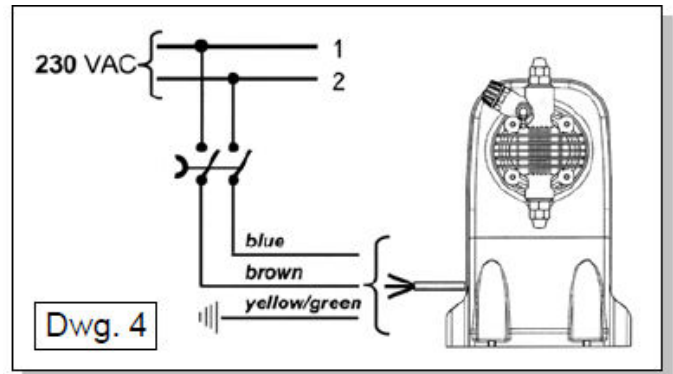

**C** Locate the pump as shown in (Dwg. 5) bearing in mind that it may be installed either below or above the level of the liquid to be dosed, though the level difference should not exceed 2 meters. When the process plant in which the pump is installed is operating at atmospheric pressure (no back pressure) and the chemical tank is situated above the plant (Dwg. 6) the condition of the injection valve should be checked at regular intervals, because excessive wear and tear could cause additive to drip into the plant even when the pump is shut down. If the problem persists, install a properly calibrate counter-pressure valve (C) between injection point and the valve.

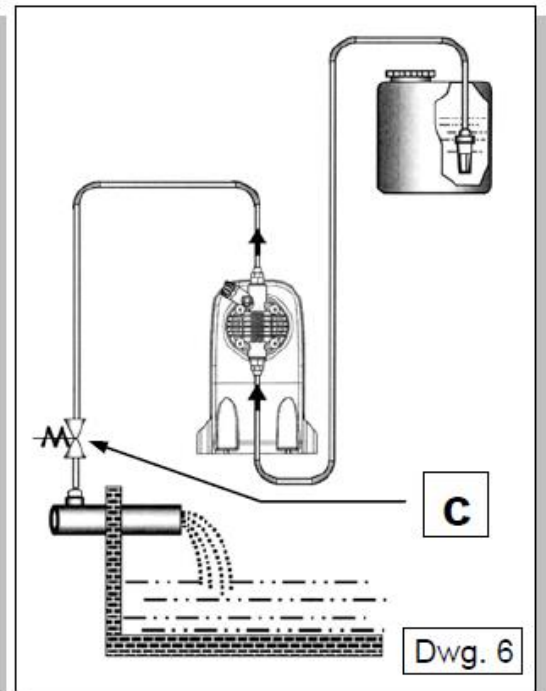
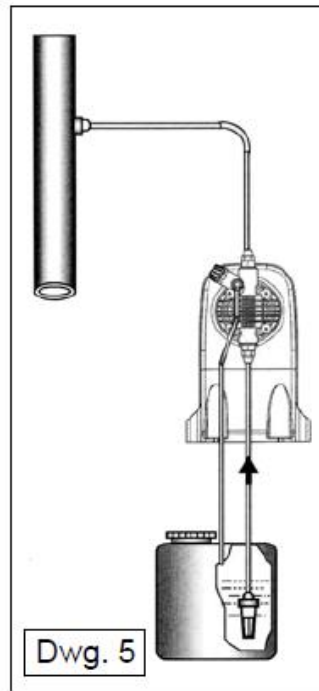

In the case liquids generates an aggressive vapours, do not install the pump above the storage tank unless the latter is hermetically sealed.

**D** The discharge nipple will always remain in the upper part of the pump. The suction nipple, which serves to attach the hose (with filter) leading into the chemical tank, will therefore always be situated in the lower part of the pump.

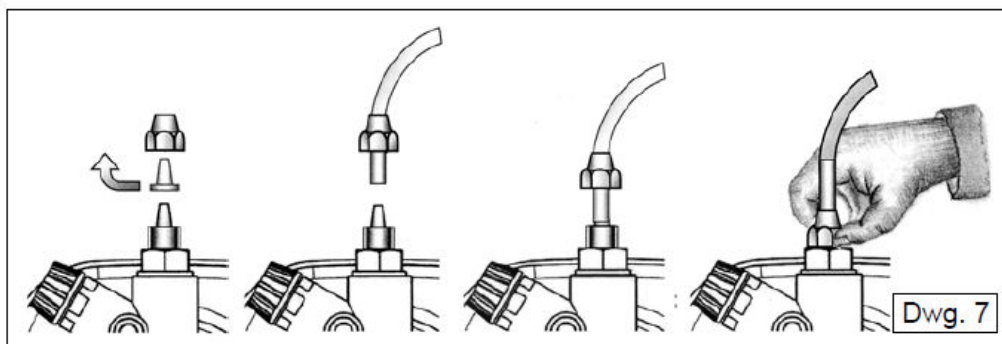

**E** Remove the protection caps from the two nipples, slide the hoses over the connectors, pushing them right home, and then fix them with appropriate tube nuts (Dwg. 7).

Whenever the pump is dismantled from the pipework, you will be well advised to replace the caps on the connectors to avoid residual liquid being spilled.

Before attaching the delivery hose to the plant, prime the metering pump by going through the sequences shown in (Dwg. 8). Before finalizing the installations of the discharge hose, make sure that the pump strokes will not cause it to move and bump into rigid bodies.



In case of priming difficulties, use a normal syringe to suck liquid from the discharge nipple while the pump is in operation, continuing until you actually syringe. Use a short length of suction hose to connect the syringe to the discharge nipple. In case of a pump equipped with an air bleed valve, unscrew the air relief valve **B** up to all the air in the pump head will be out.

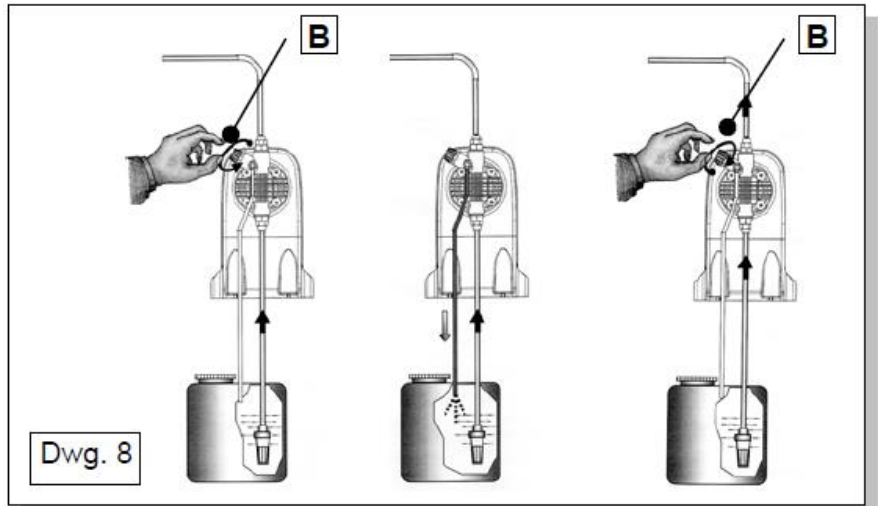

**F** Try to keep both the suction and discharge hose as straight as possible, avoiding all unnecessary bends.

**G** Select the most appropriate injection point on a pipe of the plant to be treated and there fit a 3/8" female steel gas thread connector (similar to BSPm) This connector is not supplied with the pump. Screw the injection valve to the gas connector, inserting a gasket as shown in (Dwg. 9). Then connect the discharge hose to the conical connector on the injection valve and fix it with the supplied tube nut (**G**). The injection valve also acts as no return valve by means of a cylinder sleeve (elastomer, standard supplied in Viton).

**3.1 INJECTION VALVE INSTALLATION DIAGRAM**

- A** Pipework
- C** Injection valve
- D** Cylinder sleeve (no return valve)
- M** Conical connector for attaching the discharge hose
- N** 3/8" female steel gas thread connector
- G** Hose tube nut
- T** Polyethylene hose

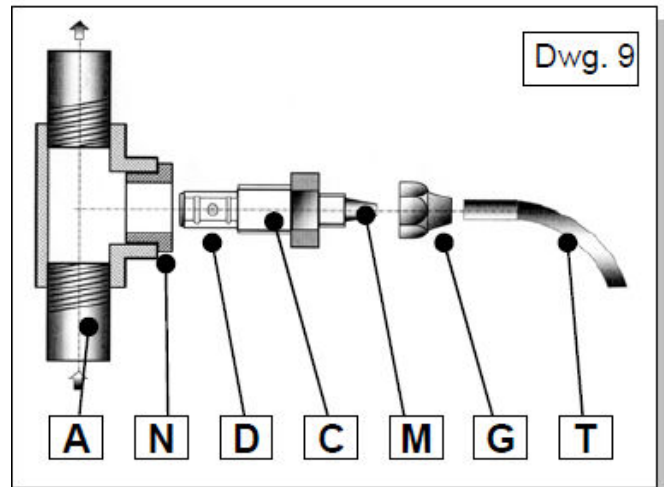

**N.B The sleeve D must not be removed**

**3.2 MANUAL STROKE LENGTH ADJUSTMENT (upon request only for SMC-R and SML-R)**

Press and turn the knob (Ref. **1**) up to the stroke length adjustment required.

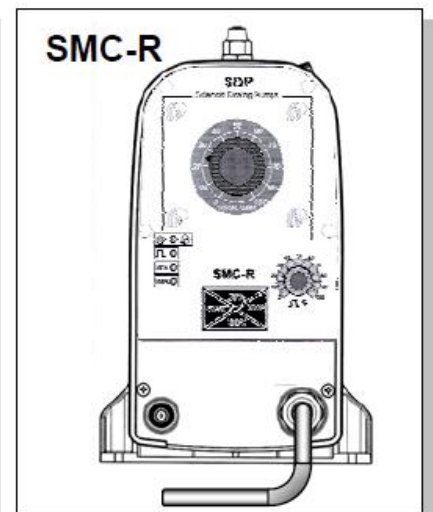
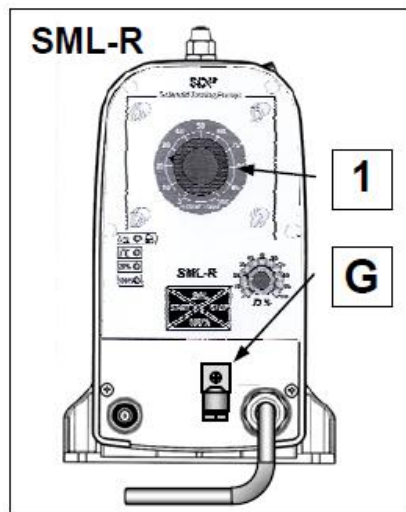
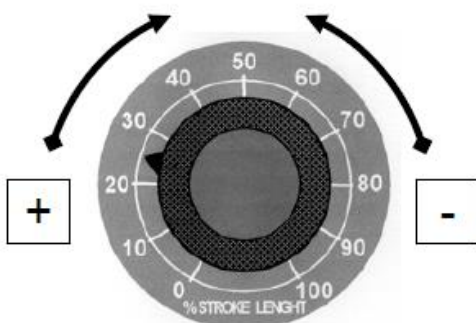

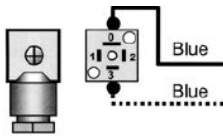

### 3.3 WIRING CONNECTION AND OUTPUT

INSTRUMENT TYPE	WIRING CONNECTOR	
<p><b>SML</b> <b>Switch level</b> <b>(G)</b></p>		<p>Pin 1 No connection Pin 2 No connection <b>Pin 3 Blue wire</b> <b>Pin 0 Blue wire</b></p>

## 4 MAINTENANCE

**1** Periodically check the chemical tank level to avoid the pump operating without liquid. This would not damage the pump, but may damage the process plant due to lack of chemicals.

**2** Check the pump operating condition at least every 6 months, pump head position, screws, bolts and seals; check more frequently where aggressive chemicals are pumped, especially:

- Pulse and power L.E.D.
- The additive concentration in the pipework; a reduction of this concentration could be caused by the wearing of the valves, in which case they need to be replaced (Dwg. 10) or by the clogging of the filter which then has to be cleaned as in point 3 here below.

**3** The company suggests periodically cleaning of the hydraulic parts (valves and filter). We cannot say how often this cleaning should be done as it depends on the type of application, we also cannot suggest what cleaning agent to use as this will depend on the additive used.

Operating suggestions when dosing sodium hypochlorite (most frequent case):

- A** Disconnect the pins from the mains or by means of a onnipolar switch with 3 mm minimum distance between the contact.
- B** Disconnect discharge hose from pipework.
- C** Remove the suction hose (with filter) from the tank and dip it into clean water.
- D** Switch on the metering pump and let it operate with water for 5 to 10 minutes.
- E** Switch OFF the pump, dip the filter into a hydrochloric acid solution and wait until the acid finishes cleaning.
- F** Switch ON the pump again and operate it with hydrochloric acid for 5 minutes in a closed circuit, with suction and discharge hose-dipped into the same tank.
- G** Repeat the operation with water.
- H** Re-connect the metering pump to the pipework.

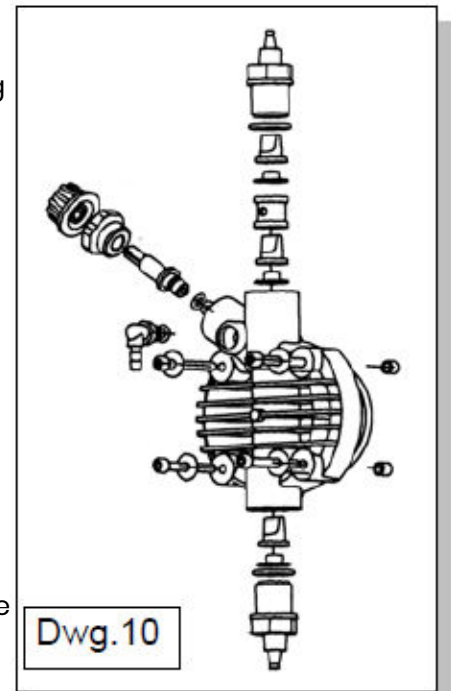

## 5 HOW TO OPERATE WHEN DOSING SULFURIC ACID (MAX 50%)

In this case it is essential to remember the following:

- 1 Replace PVC crystal suction hose with polyethylene discharge hose.
- 2 Empty any residual water from the pump head before use.

**Warning: if the water mixes with sulfuric acid it can produce a large quantity of gas with consequent** overheating of the area causing damage to valves and pump head.

This operation can also be done with the pump disconnected from the plant by turning the pump upside down for 15 to 30 seconds and without connecting the hose to the nipples; if impossible, dismount and remount the pump head (Dwg. 10) using the four mounting screws.



## 6 MANUALLY OPERATED METERING PUMP

Flow can be controlled manually by setting the pump pulse rate by means of a potentiometer. Possibility of a more precise flow rate setting at low frequencies through the two keys 20% to 100%

### 6.1 SMC- SML PUMP CONTROLS

- 1 Switch off button **"STOP"**
- 2 100% flow scale read out bottom
- 3 Switch on button **"START"**
- 4 Level alarm LED **"yellow"**  
(only on version with level alarm) **SCL**
- 5 100% flow scale read out LED **"green"**
- 6 20% flow scale read out LED **"green"**
- 7 Pulse LED **"red"**
- 8 Power LED **"green"**
- 9 20% flow scale read out button
- 10 Adjustment knob of Injections/min numbers  
(0/100% max flow)

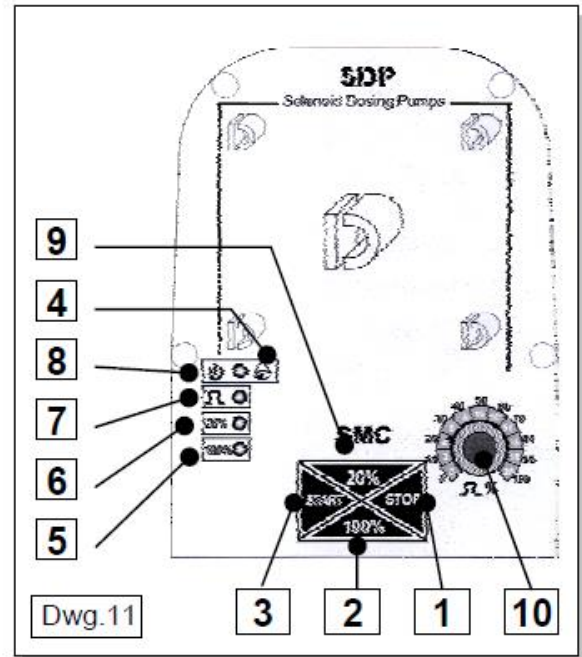

### 6.2 TYPICAL INSTALLATION

- A Power supply
- B Filter
- C Level probe
- D Chemical tank
- E Injection valve
- F Process tank

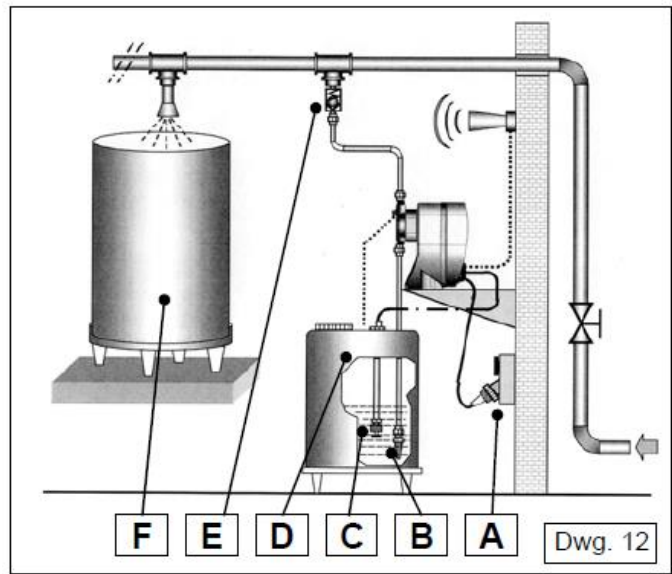

### 6.3 ACCESSORIES

- 1 N°1- Flexible PVC suction hose transparent crystal type, length 2 m.
- 2 N°1- Semirigid polyethylene hose, white, length 2 m.
- 3 N°1- injection valve 3/8 BSP m
- 4 N°1- Filter
- 5 N°1- Instructions/operating booklet

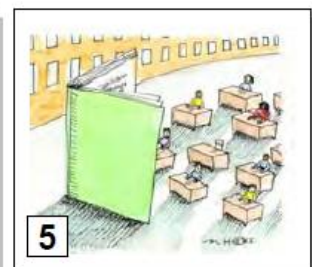
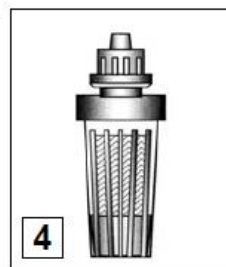
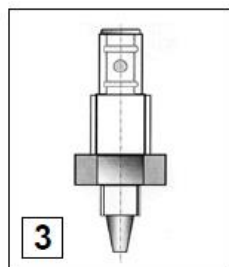
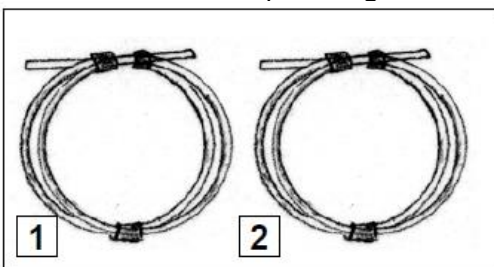





## **7 TROUBLE-SHOOTING COMMON TO SDP SERIE PUMPS**

### **7.1 MECHANICAL FAULTS**

As the system is quite robust there are no apparent mechanical problems. Occasionally there might be a loss of liquid from the nipple because the tube nut has loosened, or more simply the discharge tubing has broken.

Very rarely there may be losses caused by the breakage of the membrane, or by the membrane seals in which case they have to be replaced by disassembling the four screws of the pump head (Dwg. 10) when re-mounting the pump head ensure that the screws are replaced properly, along with "O" ring. After repair, the metering pump will need to be cleaned of additive residues which can damage the pump casing.

#### **7.1.1 THE METERING PUMP GIVES PULSES BUT THE ADDITIVE IS NOT INJECTED**

**A** Dismount the suction and discharge valves, clean them and replace, see position (Dwg. 10) Should the valves be swollen, check valves material against our chemical resistance compatibility chart and fit correct valves. Standard valves are FPM. Upon request ball check valve, can be supplied.

**B** Check clogging of the filter.

#### **ATTENTION!**

**When removing the metering pump from the plant, be careful as there might be some residual additive in the discharge hose.**

### **7.2 ELECTRICAL FAULTS**

#### **7.2.1 ALL LEDS OFF, THE PUMP DOES NOT PULSE**

Check power supply (socket, plug, power switch ON), if the pump doesn't work contact manufacturer Customer Service, Dealer or Distributor.

#### **7.2.2 GREEN LED (POWER) ON RED LED (PULSE) OFF, THE PUMP DOESN'T PULSE**

Press START button, check the flow rate adjustment knob (Rif.1) turning it to max flow rate. If the pump doesn't work contact manufacturer, Customer Service, Dealer or Distributor.

#### **7.2.3 PUMP PULSES AREN'T CONSTANT**

Check that supply voltage is within  $\pm 10\%$  of rated voltage

#### **7.2.4 THE DOSING PUMP GIVES ONLY ONE PULSE**

Disconnect the equipment and contact manufacturer Customer Service, Dealer or Distributor.

**PUMP SECTIONAL DRAWING**

**Pump construction**

**Type SML - SMC**

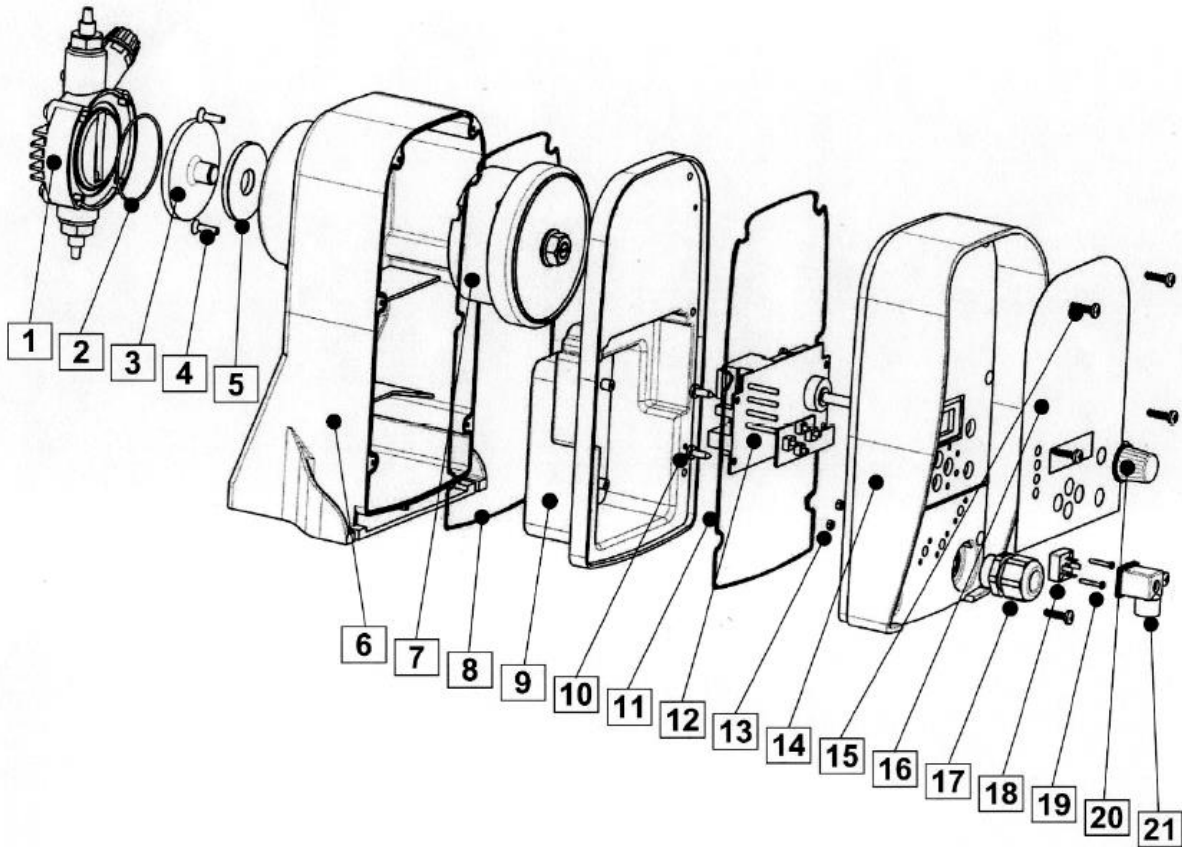

Item	N°	Spare part	Description
1	1		Pump head
2	1		O-ring gasket
3	1		Diaphragm
4	2		Screw
5	1		Flange
6	1		Pump body
7	1		Electromagnet
8	1		Gasket
9	1		Separation panel
10	4		Screw
11	1		Gasket
12	1		Electronic card
13	2		Nut
14	1		Control panel
15	6		Screw
16	1		Push-button panel
17	1		Cable gland
18	1		Male connector
19	2		Screw
20	1		Pointer knob
21	1		Female connector

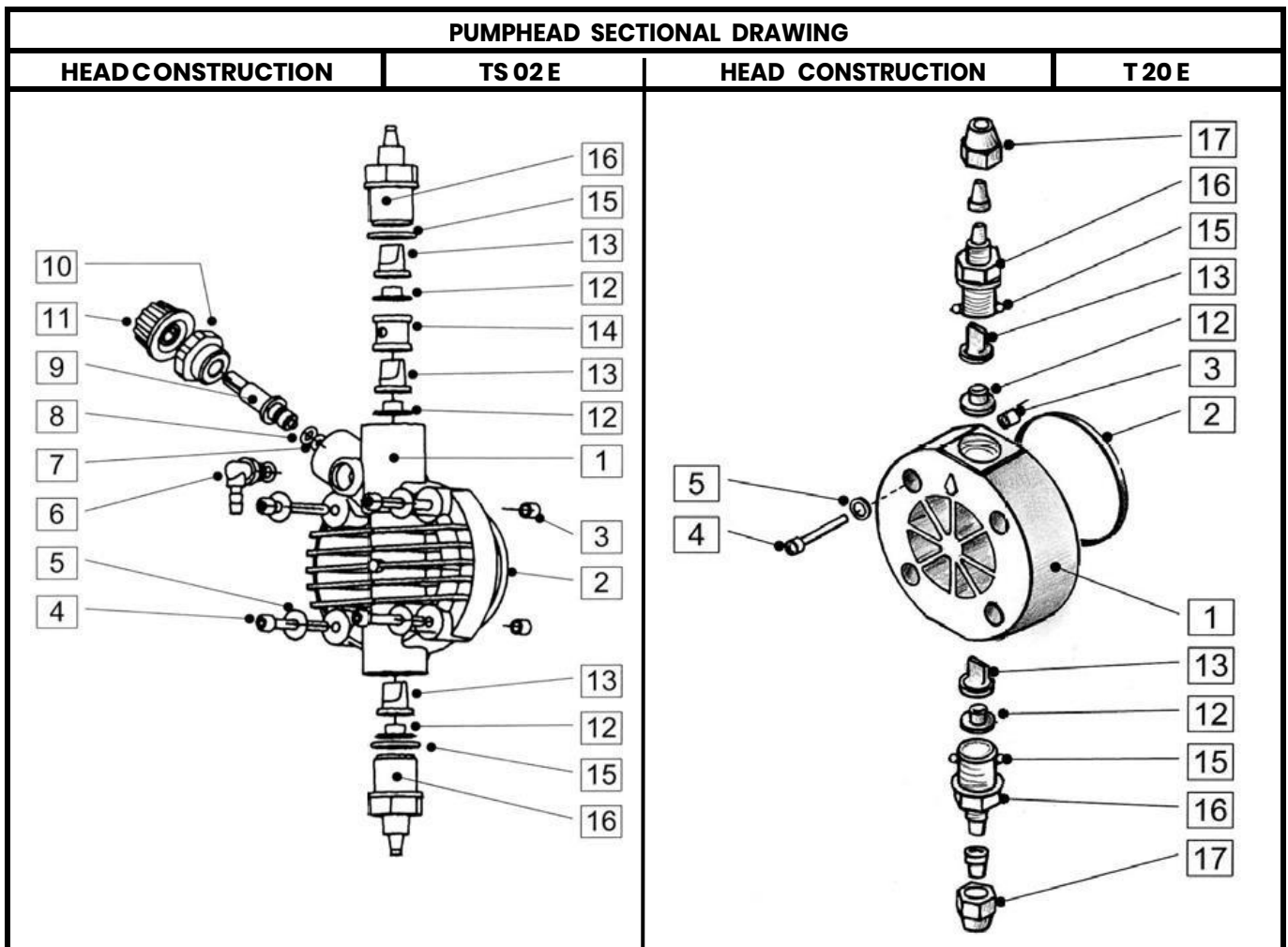

Item	N°	Spare part	Description
1	1	X	Pump head
2	1	X	O-ring gasket
3	4		Pump head bush
4	4		Screw
5	4		Flat washer
6	1		Air bleed nipple
7	1	X	O-ring gasket
8	1	X	O-ring gasket
9	1		Air bleed screw
10	1		Air bleed cap
11	1		Air bleed knob
12	3	X	Valve guide
13	3	X	Valve
14	1		Air bleed spacer
15	2	X	O-ring gasket
16	2	X	Nipple
17	2	X	Tube nut



**COMPONENTS DESCRIPTION**

VALVE			INJECTION VALVE			FILTER		
V 02			VI 02			F 20		
Item	Spare part	Description	Item	Spare part	Description	Item	Spare part	Description
12	X	Valve guide	1		Injection fitting	1		Cover
13	X	Valve	2	X	Viton sleeve	2		Screen strainer
15		O-ring gasket	/			3	X	Filtering wool
16		Valve Nipple	/			4		Separate ring
17		Tube nut	/			13	X	Valve

**ELECTROMAGNET**

**M 80 - M 90**

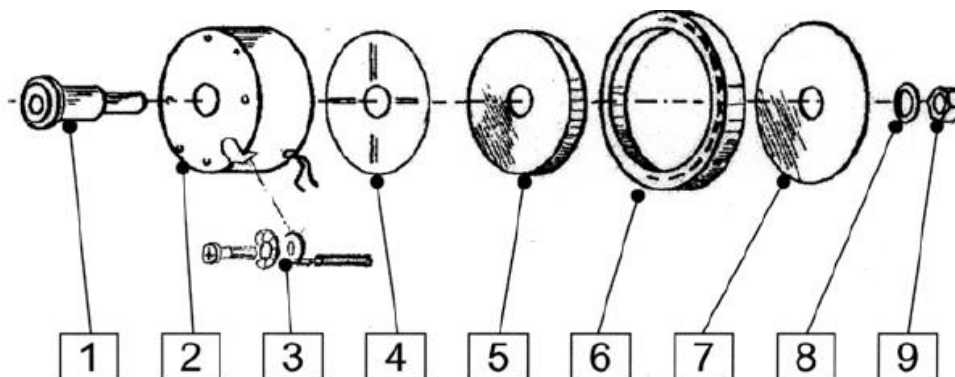

Item	N°	Spare part	Description
1	1	X	Plunger
2	1		Electromagnet
3	1		Electromagnet cable terminal
4	1	X	Aircore
5	1		Collar
6	1	X	Preloading ring
7	1	X	Cup shaped spring
8	1		Washer
9	1		Nut





PUMPHEAD SECTIONAL DRAWING			
HEADCONSTRUCTION	T 11 D	HEAD CONSTRUCTION	T 12 D
Item	N°	Spare part	Description
1	1		Pump head
7	1	X	O-ring gasket
9	6		Flat washer
14	6		Screw

COMPONENTS DESCRIPTION			
VALVE CONSTRUCTION	V11D	VALVE CONSTRUCTION	V12D
Item	N°	Spare part	Description
301	1		Suction housing
302	1		Delivery housing
307	1	X	Valve seat
309	1	X	Height limiter
310	1	X	O-ring gasket
311	1	X	O-ring gasket
312	1	X	Valve guide
313	1	X	Balls
313/1	1	X	Balls
319	1	X	Double valve using
324	1		Locking bush
330	1		Protection top



TO MEASURE  TO KNOW

---

**Nieuwkoop BV**

Aalsmeerderweg 249 -S

1432 CM AALSMEER

0297 325836

[info@nieuwkoopbv.nl](mailto:info@nieuwkoopbv.nl)

[www.meten.nl](http://www.meten.nl)



**NIEUWKOOP**